

1950<sup>HD</sup>  
commercial

# JANUS<sup>®</sup> [International]



*superior product + recognized value*



# JANUS<sup>®</sup>

[International]

*The Model 1950 HD is a sheet door value engineered with strength and durability in mind. Universal mount 4" deep 12 gauge galvanized steel guides securely engage the door curtain. The versatility and easy operation make this door dependable, yet still economical. Backed by a one year warranty on workmanship and material, this heavy duty Model 1950 HD is the best value on the market.*

## FEATURES



The 26 gauge corrugated door curtain is manufactured from full hard galvanized grade 80 steel and coated with Super Durable Polyester paint that is backed by a 40 year film integrity and a 25 year no-fade limited paint warranty. Available in sizes up to 12'0" x 14'0" and in over 20 different colors.

Tough, durable and wide, heavy duty nylon strapping helps control curtain stretch while deadening sound and reducing wear.

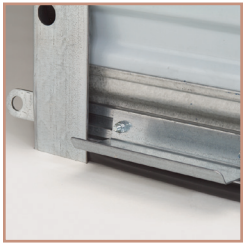
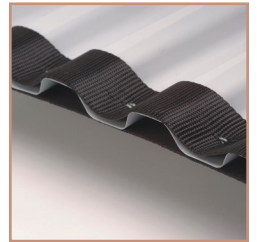

The slide bolt lock assembly affixed to the bottom bar at each end of the door curtain fastens through the guide to securely keep the door locked and in the down position. Padlocks can be attached to the slide to further secure the door.

The flat door stop slide makes installation quicker. Simply slide through the hub through the slot on the guide and affix with a fastener.



9-1/2" diameter drums allow for lower headroom requirements. An enclosed barrel houses the dead axle assembly and protects the factory lubricated springs from direct contact with environmental elements. The inherent strength provided by the spiral barrel minimizes axle deflection providing smoother operation. Because the curtain is attached by screws and not seamed to the barrel, replacement of either independent assembly is cost-effective, quick and easy.

Grease-filled, shielded radial ball bearings at the drums provide longevity and smooth operation. Factory installed insert nuts help make the installation of the chain hoist and operator sprocket easier.



A cam-action spring tension holding device allows quick, easy and equal adjustment of the tension on all springs simultaneously from one end of the door. The cam tensioner bites into the axle helping to eliminate the unwanted spinning of the axle during the initial spring loading or adjustment process.



A reduced drive chain hoist allows for smoother operation on doors over 10'0" wide or 10'0" tall.

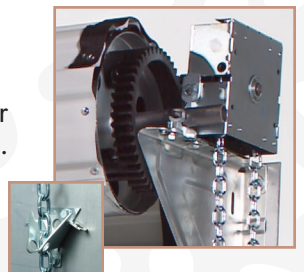

superior product + recognized value

Three manufacturing facilities located throughout the United States and a team of experienced door experts to assist you with any of your door needs.

# 1950<sup>HD</sup> commercial

One year warranty on workmanship and material.

Mounting brackets are engineered and designed with deep embossing for strength, and are independently tested to withstand more than 1,200 pounds per pair. The installation-friendly mounting brackets feature safe rounded edges and slots that allow for easy vertical adjustments as well as various installation preferences.

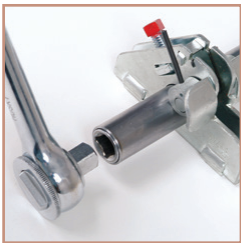

Convenient spring tension adjustment is accommodated by inserting a common 3/8" ratchet tool into the end of the drive shaft and rotating. Initial loading of the door tension can be easily accomplished with a ratchet without the difficulty of spinning the door. This innovation also allows the tension to be easily measured and managed with a torque wrench.

## OPTIONS

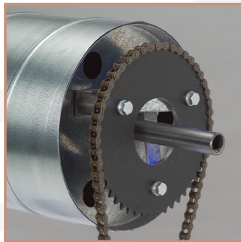

The electrical operation kit includes a sprocket and torque struts that equip the door for wall mounted jackshaft electric operators and can be furnished in lieu of reduced drive chain hoist when provided.

Insulation is made of a foil backed, dual layer of heavy-duty polyethylene air-bubble insulation secured in place with a strong adhesive and joined by mylar film (top draft stop and side draft stops are also included.)

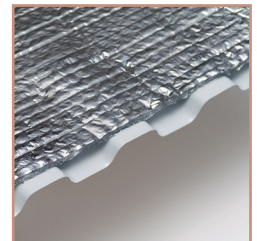

The header seal attaches directly to the header and extends up to 5" to the door curtain to form an effective barrier from environmental elements.

The top draft stop mounted to the door curtain provides a 2-1/4" weather seal between the door and the header.

## GUIDE DETAILS

Universal mount 4" deep 12 gauge galvanized steel guides require no pre-installation modifications for wood, steel, concrete or masonry block applications.

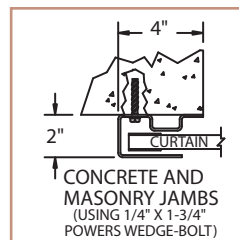
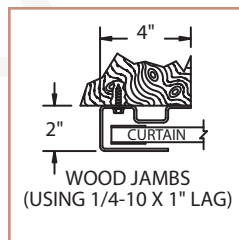
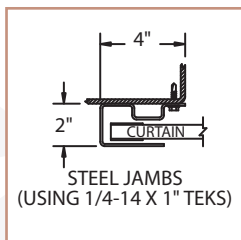

## Side Room Requirements

| Operation           | Guide | Outside of Bracket Tensioner End | Outside of Hand Chain Drive | Outside of Bracket Drive End | Each End of Axle |
|---------------------|-------|----------------------------------|-----------------------------|------------------------------|------------------|
| Push Up             | 4"    | 5- 5/8"                          | N/A                         | 5- 5/8"                      | 8- 1/2"          |
| Reduced Drive Chain | 4"    | 5- 5/8"                          | 8- 1/2"                     | 7"                           | 8- 1/2"          |
| Electric            | 4"    | 5- 5/8"                          | N/A                         | 7- 1/8"                      | 8- 1/2"          |

### IMPORTANT NOTES:

- Dimensions are referenced from edge of opening.
- Tensioner end and drive end can be installed at either end of door assembly.
- FOR CRITICAL FITS DUE TO REDUCED AVAILABLE HEADROOM or SIDEROOM CLEARANCES < CONSULT FACTORY.

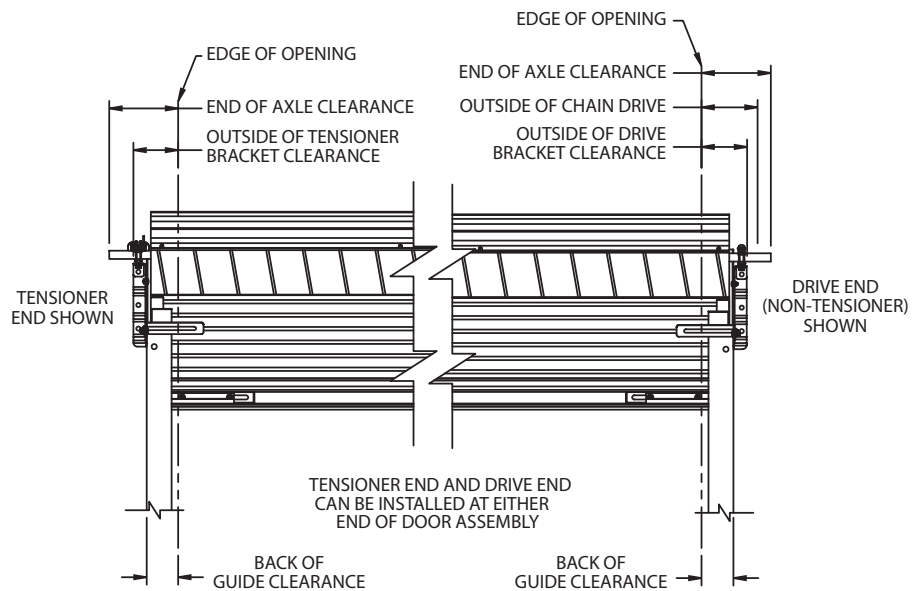
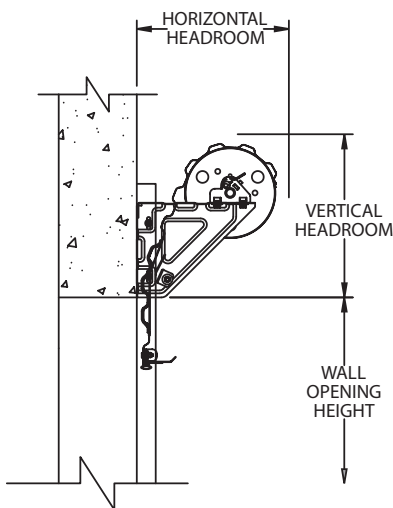

## JANUS INTERNATIONAL

{ headquarters }  
p.o. box 567  
temple, georgia 30179

{ manufacturing facilities }  
135 janus international blvd  
temple, georgia 30179

+  
1256 brittmoore road  
houston, texas 77043

+  
13374 west peoria avenue  
surprise, arizona 85379

{ distribution centers }  
2535 west la palma avenue  
anaheim, california 92801

+  
10407 rocket blvd.  
orlando, florida 32824

PH **1 866 562 2580**  
FX **1 770 562 0328**  
[www.janusintl.com](http://www.janusintl.com)

## Head Room Requirements

| Opening Height        | Vertical Headroom | Horizontal Headroom |
|-----------------------|-------------------|---------------------|
| Thru 8'0"             | 19"               | 19"                 |
| Over 8'0" thru 10'0"  | 20"               | 20"                 |
| Over 10'0" thru 14'0" | 20 1/2"           | 20"                 |

proud members of:

