

# 3652

*commercial*



# JANUS

INTERNATIONAL



*superior product + recognized value*





**JANUS**  
INTERNATIONAL

*The Janus Model 3652 is our certified wind load rated rolling sheet door that meets specified wind loads required by even the most stringent building codes. Independent laboratory testing proves how durable and strong this door really is. The quick installation and smooth operation further demonstrates how user friendly this door is. Backed by a one year warranty, this door is built to perform.*

## FEATURES

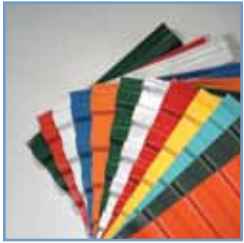

The 26 gauge corrugated door curtain is manufactured from full hard galvanized grade 80 steel and coated with Super Durable polyester paint that is backed by a 40 year film integrity and 25 year no-fade limited paint warranty. Independently tested in accordance with ASTM E 330 and ANSI/DASMA 108, the series 3652 meets requirements of the International Building Code and Florida Building Code (FL 14425). Design wind load is rated +36 PSF and -40 PSF for opening width of 12'0". Ratings vary for other opening widths, so please consult the factory. Available in sizes up to 18' wide x 14' high and in over 20 different standard colors.



Tough, durable and wide, heavy duty nylon strapping helps control curtain stretch while deadening sound and reducing wear. The nylon windlocks provide the strength to meet the stringent wind load requirements when engaged under load; however, easy operation is provided during load-free operation because the windlocks do not come in contact with guide.

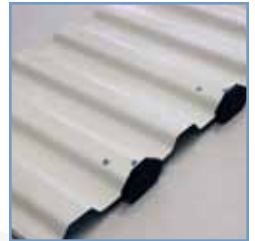

The slide bolt lock assembly affixed to the bottom bar at each end of the door curtain fastens through the guide to securely keep the door locked and in the down position. Padlocks can be attached to the slide to further secure the door.

The flat door stop slide makes installation quicker. Simply slide through the holder on the guide and affix with a fastener.

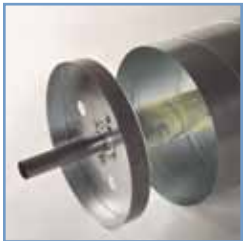

The 12" enclosed barrel houses the dead axle assembly and protects the factory lubricated springs from direct contact with environmental elements. The inherent strength provided by the spiral barrel minimizes axle deflection, providing smoother operation. Because the curtain is attached by screws and not seamed to the barrel, replacement of either independent assembly is cost-effective, quick and easy.

Grease-filled, shielded radial ball bearings at the drums provide longevity and smooth operation. Factory installed insert nuts help make the installation of the chain hoist and operator sprocket easier.



A cam-action spring tension holding device allows quick, easy and equal adjustment of the tension on all springs simultaneously from one end of the door. The cam tensioner bites into the axle helping to eliminate the unwanted spinning of the axle during the initial spring loading or adjustment process.



A reduced drive chain hoist for smoother operation is standard on all door sizes over 10'0" x 10'0".



superior product + recognized value

Three manufacturing facilities located throughout the United States and a team of experienced door experts are available to assist you with any of your door needs.

# 3652

commercial

One year warranty on workmanship and material.

Mounting brackets are engineered and designed with deep embossing for strength, and are independently tested to withstand more than 2,700 pounds per pair. The installation-friendly mounting brackets feature safe rounded edges and slots that allow for easy vertical adjustments as well as various installation preferences.



Convenient spring tension adjustment is accommodated by inserting a common 1/2" ratchet tool into the end of the axle and rotating. Initial loading of the door tension can be easily accomplished with a ratchet without the difficulty of spinning the door. This innovation also allows the tension to be easily measured and managed with a torque wrench.



## OPTIONS



The electrical operation kit includes a sprocket and torque struts that equip the door for wall mounted jackshaft electric operators and can be furnished in lieu of reduced drive chain hoist when provided.

The Pantheon range of low voltage DC operators are designed to fit enclosed internally in the barrel of the rolling door, providing quiet and efficient operation but requiring only minimal side room. The logic controller is designed to be readily compatible with external transmitters, receivers, photo eyes and sensing edges. The operator hand side must be specified when ordering. Ask a sales representative for more details.

Insulation is made of a foil backed, dual layer of heavy-duty polyethylene air-bubble insulation secured in place with a strong adhesive and joined by mylar film. (Top draft stop and side draft stop are also included.)

The header seal attaches directly to the header and extends up to 5" to the door curtain to form an effective barrier from environmental elements.



The top draft stop mounted to the door curtain provides a 2-1/4" weather seal between the door and the header.

## GUIDE DETAILS

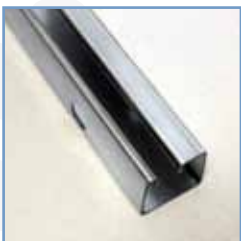

Universal mount 2" deep 14 gauge galvanized steel guides require no pre-installation modifications for steel, concrete or filled masonry block applications.

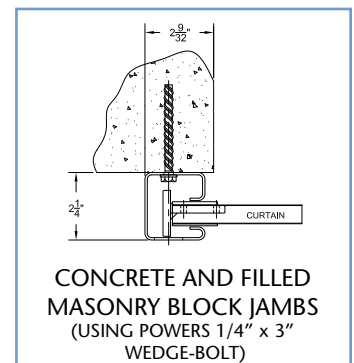
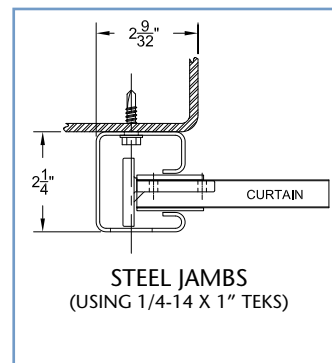

# 3652

commercial

superior product + recognized value

## Side Room Requirements

\*Dimensions are taken from edge of opening

Operation	Back of Guide	Outside of Bracket Tensioner End	Outside of Hand Chain Drive	Outside of Bracket Drive End	End of Axle Clearance
Push Up	2- 9/32"	3- 7/8"	N/A	3- 7/8"	6- 3/4"
Reduced Drive Chain Hoist	2- 9/32"	3- 7/8"	6-1/8"	3- 7/8"	6- 3/4"
Electric	2- 9/32"	3- 7/8"	N/A	5- 3/8"	6- 3/4"
Pantheon	2- 9/32"	3- 7/8"	N/A	6- 3/8"	10- 3/4"

### IMPORTANT NOTES

- Dimensions are referenced from edge of opening.
- Tensioner end and drive end can be installed at either end of door assembly.
- FOR CRITICAL FITS DUE TO REDUCED AVAILABLE HEADROOM or SIDEROOM CLEARANCES, CONSULT FACTORY.

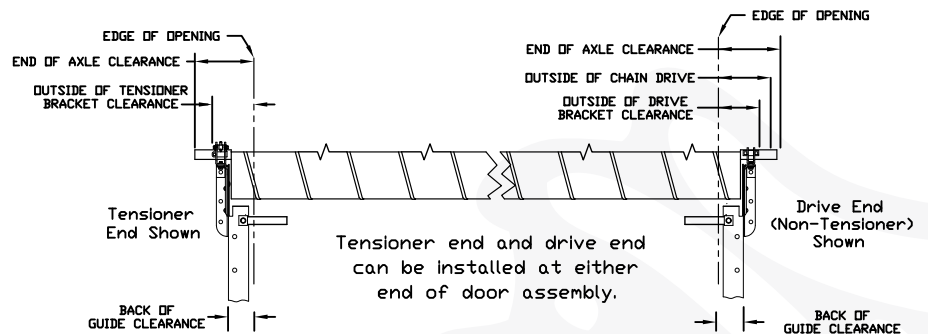
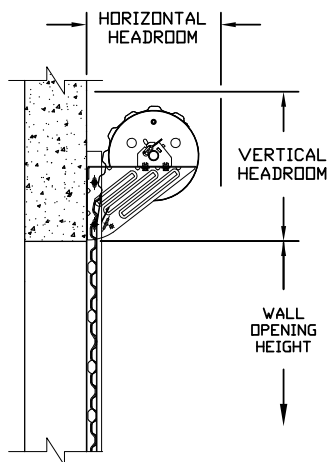

## Head Room Requirements

Opening Height	Vertical Headroom	Horizontal Headroom
Thru 8'0"	20"	20"
Over 8'0" thru 10'0"	21"	21"
Over 10'0" thru 14'0"	21 1/2"	21"

## JANUS INTERNATIONAL

{ headquarters }  
p.o. box 567  
temple, georgia 30179

{ manufacturing facilities }  
134 janus international blvd  
temple, georgia 30179

+  
1256 brittmoore road  
houston, texas 77043

+  
13374 west peoria avenue  
surprise, arizona 85379

{ distribution centers }  
2535 west la palma avenue  
anaheim, california 92801

+  
10407 rocket blvd  
orlando, florida 32824

PH 1 866 562 2580  
FX 1 770 562 0328  
www.janusintl.com



proud members of:

